

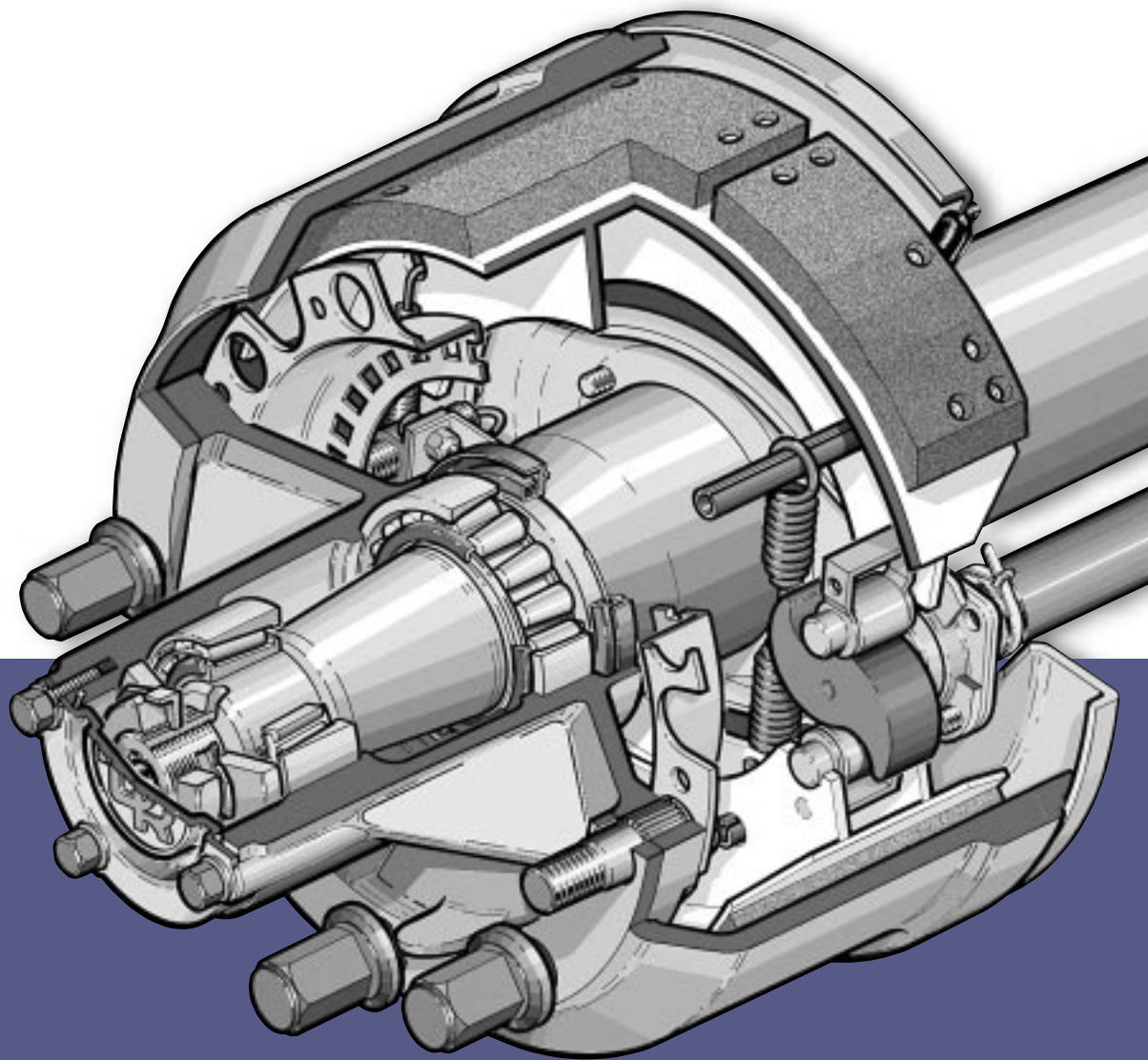

an **ArvinMeritor** brand

Meritor TE Series Axle Parts List



ArvinMeritorTM



an ArvinMeritor brand

TE Parts List

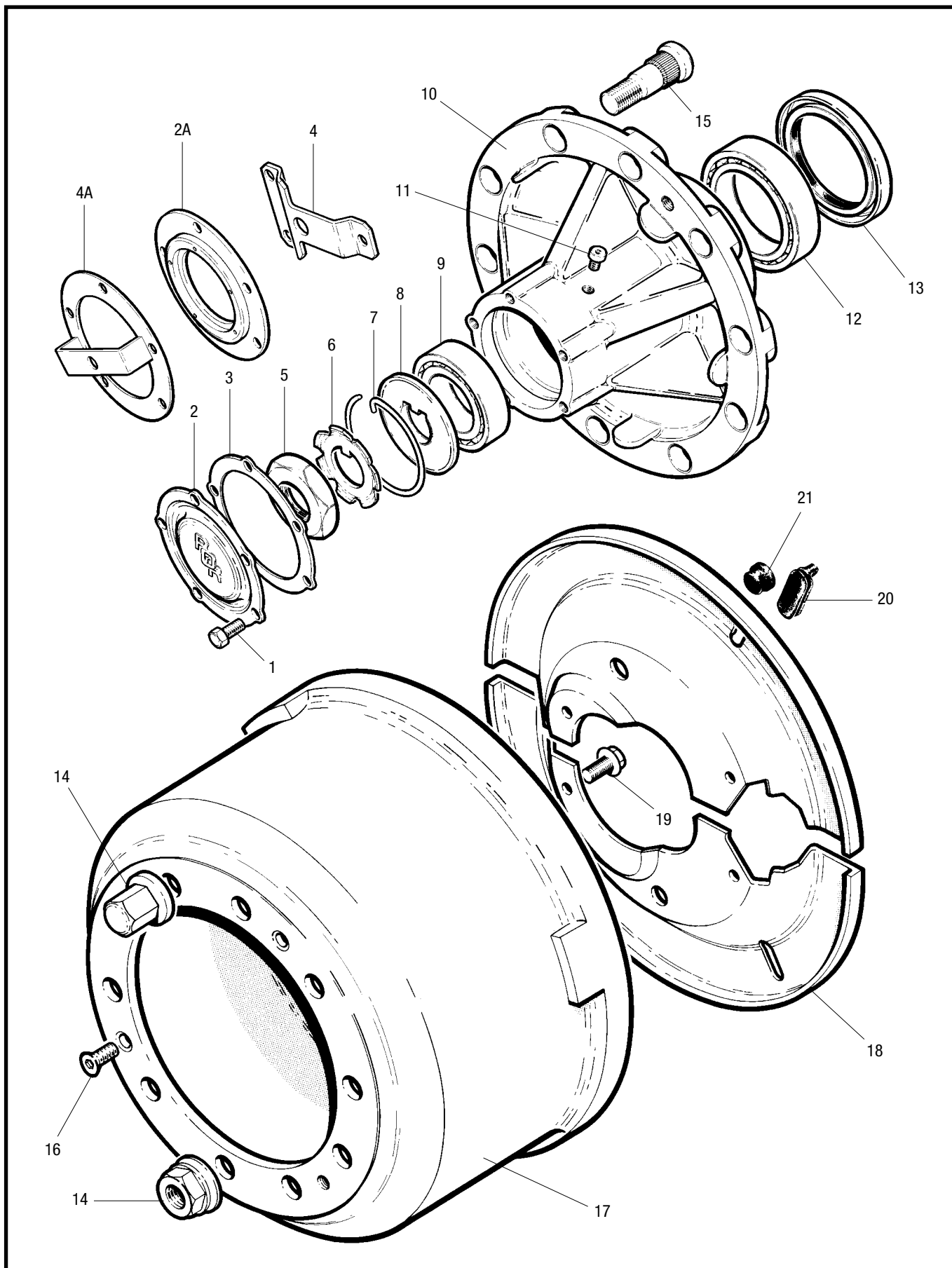

TE Parts List

TE Hub Assembly Parts List

Item	Description	Part Number
1	Screw, hub cap	99140001
2	Hub cap, grease-filled	21220727
2	Hub cap, grease-filled, hubodometer (Jost)	21221060
2A	Hub cap, oil-filled	21223807
3	Gasket, hub cap	21223797
4	Hubodometer mounting plate (Accutrak & Engler)	21222610
4A	Odometer mount, oil filled	21223835
5	End nut	21220759
6	Lock washer	21221061
7	Spring clip	21223127
8	Retaining washer	21220726
9	Bearing, outer	99041068
10	Hub	21219784S
10	Hub, oil-filled	21221162S
11	Plug, oil-filler	21221072
12	Bearing, inner	99041067
13	Oil seal	21220158
14	Wheel nut, 32mm A/F, steel wheel, open	21218643
14	Wheel nut, 32mm A/F, steel wheel, closed	21218645
14	Wheel nutt, 32mm A/F, aluminium wheel, open	21218644
15	Wheel bolt, steel wheel	21220132
15	Wheel bolt, aluminium wheel	21220969
16	Screw, brake drum retaining	99539001
17	Brake drum	21220183S
18	Dust cover assembly	21220647/15220648
19	Screw, dust cover	99535001
20	Plug, inspection	21220719
21	Plug, blanking	21211385
22	Bearing grease, Total Multis Complex EP2 (not illustrated)	99538005



an ArvinMeritor brand

TE Parts List

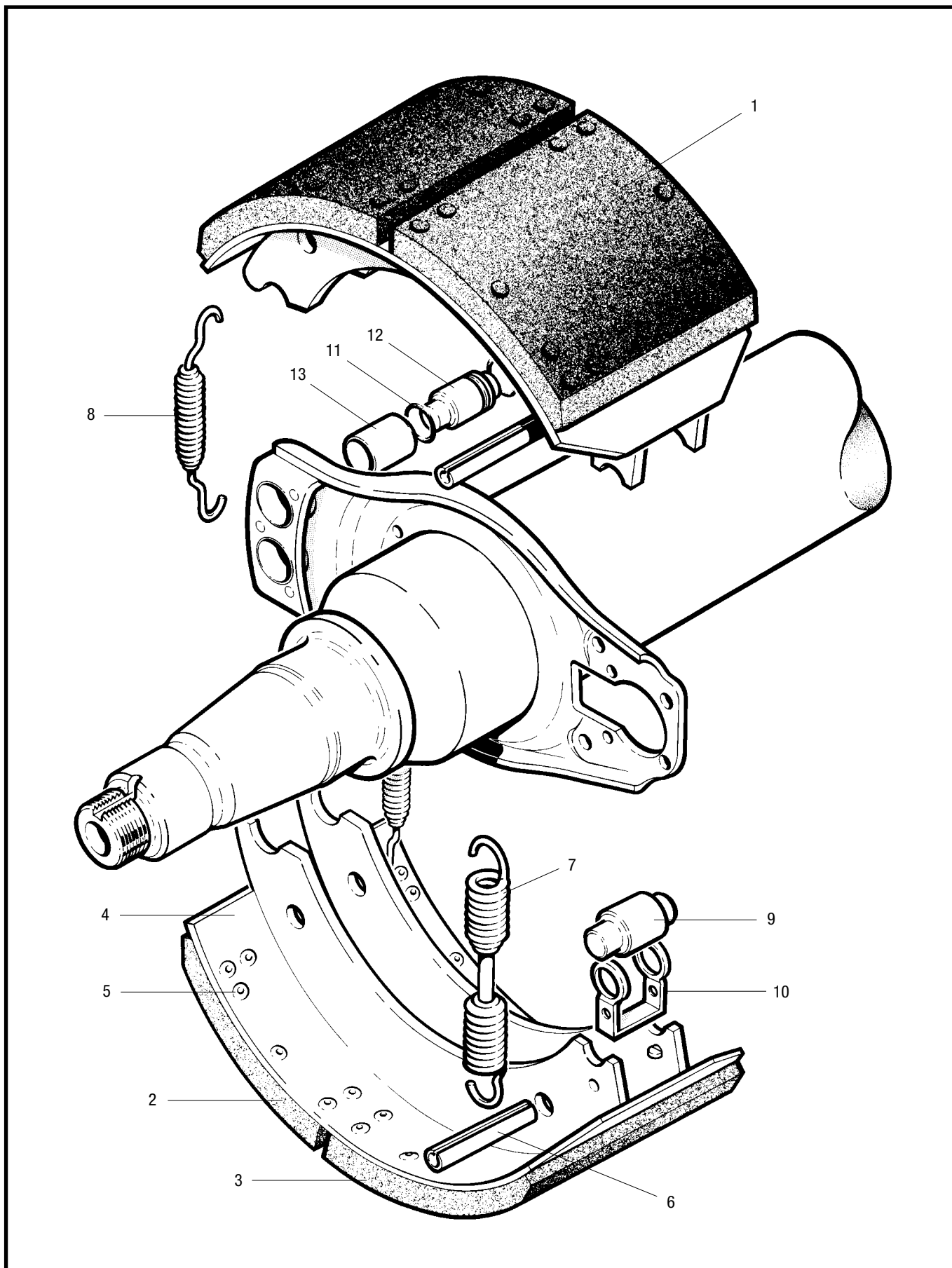



an ArvinMeritor brand

TE Parts List

Brake Assembly Parts List

Item	Description	Part Number
1	Brake shoe lined assembly	15205536E
2	Lining, anchor end	21200790E
3	Lining, cam end	21200791E
4	Brake shoe, unlined	15205533
5	Rivet	21200761
6	Roll pin	21220171
7	Return Spring	21221224
8	Retaining spring	21205194
9	Cam roller	21006610
10	Retaining clip	21023758
11	O-ring, anchor pin	21220668
12	Anchor pin	21205193G
13	Bush, anchor pin	21221028



an ArvinMeritor brand

TE Parts List

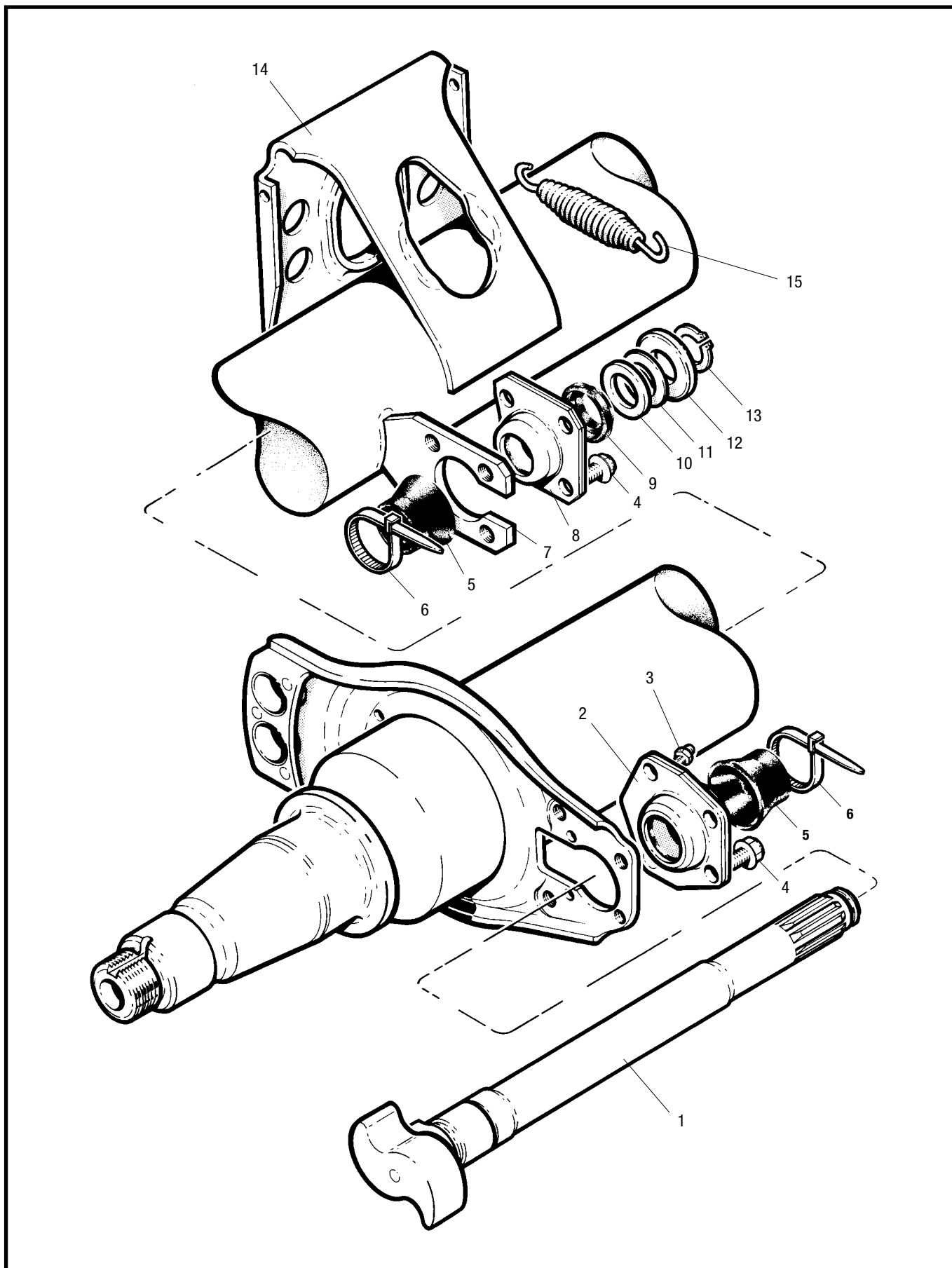

TE Parts List

Camshaft Assembly Parts List

Item	Description	Part Number
1	Camshaft, RH, dimension B = 525.5mm	21221070
1	Camshaft, LH, dimension B = 525.5mm	21221071
1	Camshaft, RH, dimension B = 587.5mm	21221194
1	Camshaft, LH, dimension B = 587.5mm	21221195
2	Spherical bearing, head end	15220224
3	Grease nipple	99040016
4	Screw, spherical bearing	99535001
5	Boot, large	21204849
6	Tie-wrap	21221065
7	Camshaft bracket	21220982
8	Spherical bearing, spline end	15213430
9	Boot, small	21205667
10	Washer, spacing, thick	21006627
11	Washer, spacing, thin	21006662
12	Washer, retaining	21219862
13	Circlip	99507030
14	Air chamber bracket	21221004
15	Assister spring	21210215

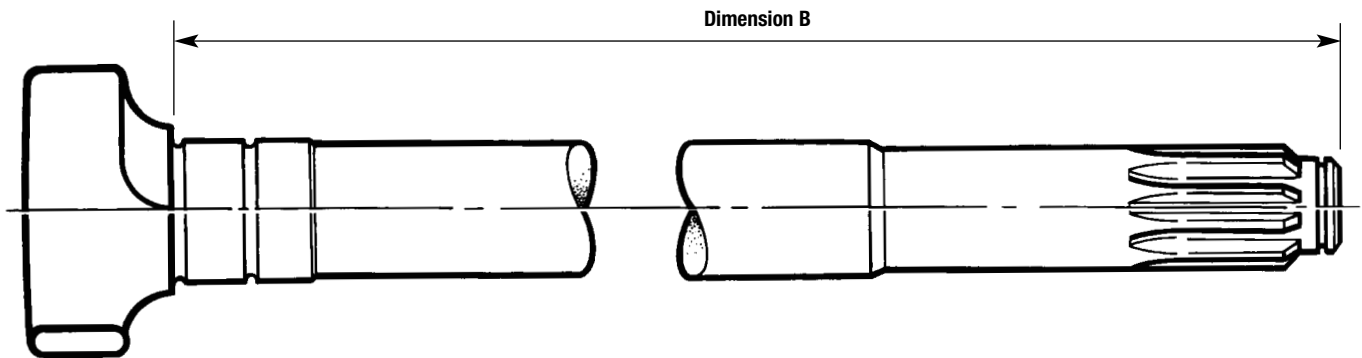



an ArvinMeritor brand

TE Parts List

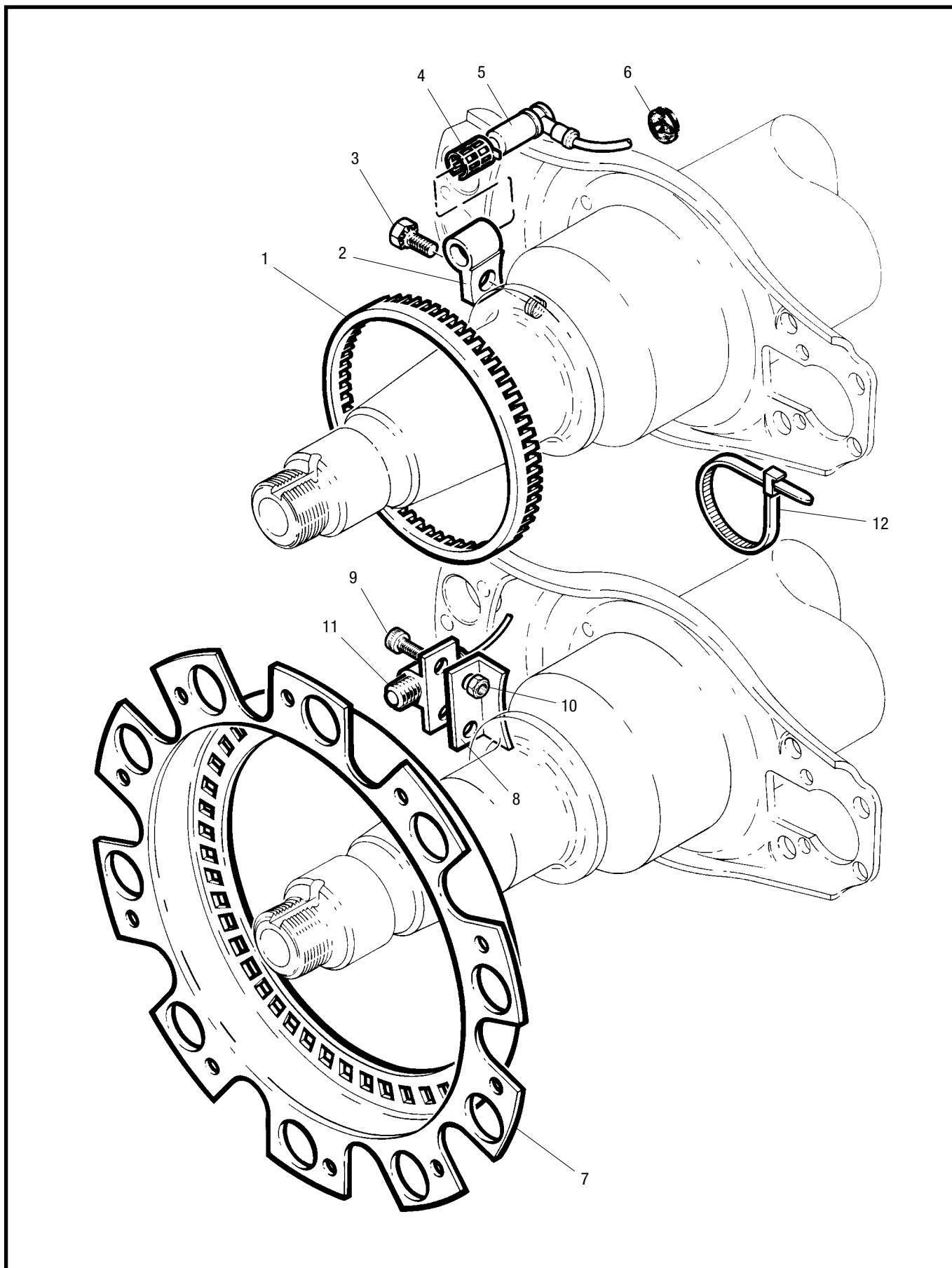

TE Parts List

Anti Lock Parts List

Item	Description	Part Number
1	Pole wheel, 100 tooth ABS	21221064
2	Sensor mounting block, 100 tooth ABS	22221063
3	Screw, sensor mounting block, 100 tooth ABS	99541001
4	Spring bush	21213036
5	Sensor assembly, 100 tooth ABS	21213034
6	Grommet (60 tooth ABS)	21220842
6	Strain relief bush (100 tooth ABS)	21222319
7	Exciter ring, 60 window ABS	21209515
8	Sensor mounting bracket, 60 window ABS	21222193
9	Screw, sensor mounting bracket, 60 window ABS	21209518
10	Locknut	21209519
11	Sensor assembly, 60 window ABS	21209517
12	Cable tie	21221065

Axle Type

Identifying your Axle Type

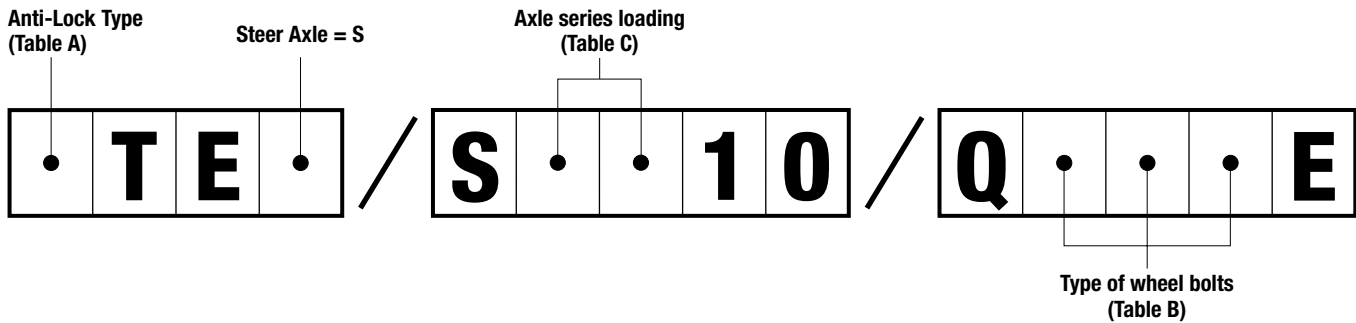

Table A

Axle Letter Code	Exciter Ring Type	Suitable For
A	60T Pressed Steel	Grau MGX2 & MGX2E Bendix MDR & MDRA
W	100T Solid Ring	Wabco Bosch Grau DGX & MGX100

Table C

Axle Series	Nominal Highway Axle Rating kg	Wall Thickness mm	Maximum Offset* mm
90	9,300	13	460
93**	9,300	16	490

The axle ratings shown are for normal highway applications and any special application for installation must be approved by Meritor Design Engineering.

* NB: Offset = $\frac{\text{Track} - \text{spring centres}}{2}$

** For use with non Meritor air suspensions

Table B

Axle Letter Code	ISO 4107 Wheel mounting type
MX	M22 x 1.5mm wheel studs for single steel wheels
MXA	M22 x 1.5mm wheel studs for single alloy wheels

Identifying the Serial Number

Non Asbestos Brake Lining

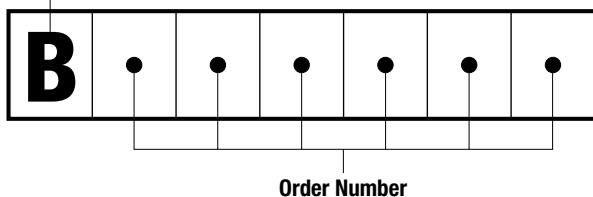

Build Month

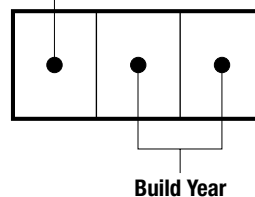

Sequential Number

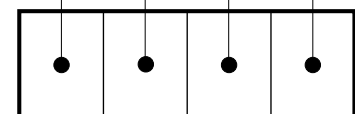

Warranty

A comprehensive network of original parts distributors and service stations operate throughout Europe; this is supported internationally with agents strategically placed around the world.

All Meritor replacement parts obtained through original parts distributors are covered by a one year warranty.

For full warranty terms and conditions see 'Meritor Warranty Terms and Conditions' Publication No 4.84.1

Meritor reserve the right to make changes in specifications shown herein or add improvements at any time without notice or obligation.

PARTS SHOWN IN THIS SPARES LIST ARE MADE FROM DRAWINGS IN WHICH COPYRIGHT SUBSISTS. THE MAKING OF COPIES OF ANY OF THESE PARTS IS PROHIBITED.

© Meritor HVS Limited



The high quality assurance management systems applied by Meritor are endorsed with the awarding of ISO 9001, Lloyd's Register Quality Assurance.

Meritor HVS Limited
Commercial Vehicle Systems
Rackery Lane, Llay
Wrexham LL12 0PB
U.K.
Telephone: +44 (0)1978 852141
Fax: +44 (0)1978 856173

Meritor HVS (Mityr-Mory) S.A.
Commercial Vehicle Systems
Z.I. du Moulin à Vent
9 rue des Frères Lumière
77290 Mityr-Mory
France
Telephone: +33 (0)1 64.27.44.61
Fax: +33 (0)1 64.27.30.45

Meritor HVS (Verona) s.r.l.
Commercial Vehicle Systems
Via Monte Fiorino, 23
37057 San Giovanni Lupatoto
Verona
Italy
Telephone: +39 045 8750399
Fax: +39 045 8750640 / 8750513

Meritor HVS (Barcelona) S.A.
Commercial Vehicle Systems
Ctra. Granollers - Sabadell Km. 13,3
Poligono Argelagues
08185 Lliçà de Vall
Spain
Telephone: +34 (9)3 843 95 68
Fax: +34 (9)3 843 83 59

ArvinMeritor Inc.
World Headquarters
2135 West Maple Road
Troy, Michigan 48084
U.S.A.
Telephone: +1 248 435 1000

ArvinMeritor
Commercial Vehicle Aftermarket AG
Neugutstrasse 89
8600 Dübendorf
Switzerland
Telephone: +41 (0)1 824 8200
Fax: +41 (0)1 824 8264

ArvinMeritor
Commercial Vehicle Systems
Postbus 255
5700AG Helmond
Churchillaan 204A
5705BK Helmond
Holland
Telephone: +31 (0)492 535805
Fax: +31 (0)492 547175

ArvinMeritor South Africa
Commercial Vehicle Systems
Telephone: +27 (0) 83 602 1603

For further information contact

Meritor HVS Limited
Commercial Vehicle Systems
Rackery Lane, Llay
Wrexham LL12 0PB
U.K.
Telephone: +44 (0)1978 852141
Fax: +44 (0)1978 856173

www.arvinmeritor.com

© Copyright 2001
Meritor Automotive
All rights Reserved

Publication 4.37.6

Descriptions and specifications were in effect at the time of publication and are subject to change without notice or liability. Meritor reserve the right to make design improvements, change or discontinue parts at any time.

ArvinMeritor™